

ParagonLED Radiation Hardened Lighting

Advanced Shielded Lighting for Radiological Environments



CERTIFIED
UL 1598

IP66



CB FC



- Radiation Hardened LED task light engineered for temperature extremes, wet environments, and long-term reliability.
- Certified radiation hardness up to 1000 kGy / 100 Mrad (megarad).
- Features radiation-hardened components and multiple shielding solutions to increase longevity in high-radiation environments.
- LED module includes several layers of radiation protection.
- Ambient operating temperature: -80°C (-112°F) to 115°C (239°F).
- Proprietary driver-on-board (driver-less) LED modules.
- Replaceable LED modules for low long-term cost and extended fixture life.
- quartz glass: Fully resistant to radiation-induced darkening, ensuring long-term light transmission.
- Fully lead-free design avoids export, environmental, and waste-management restrictions related to lead.
- Special stainless-steel components using low-cobalt or cobalt-free alloys reduce the risk of creating long-lived activation isotopes.
- Lower decommissioning and disposal costs.
- Long lifespan × high reliability: At 55°C, L70 light-output lifetime exceeds 15 years.
- >20 kV surge protection.
- Available in single, double, or triple configurations.
- High vibration resistance using Nord-Lock® washers.
- Optional chemical-repellent PVDF coating for extreme corrosion resistance.
- AWM style 4476 — 600 V / 200°C rated power cord, stainless-steel cable gland.
- Trade Agreement Act (TAA) compliant.
- Non-Safety-Related zones: Plug-and-play, no additional certification required.

Radiation Test	
GAMMA dose speed	6.0 kGy/h
Total GAMMA dose	1000kGy
fast-neutron fluence	~4.46 × 10 ¹⁴ n/cm ² , 1 MeV equivalent

Exposure to GAMMA radiation and fast-neutron fluence was tested in National Atomic Energy Research Institute (NARI).

Specification

Voltage	100VAC /120VAC /200VAC /208VAC /230VAC /250VDC /277VAC /347VAC /480VAC /600VAC	Lens	Quartz Glass
Frequency	50Hz/60Hz	Cable Gland	Stainless steel
Wattage	500W	IP Protection	IP66
Color Temp	5000K	Surge Protection	>20kV
Housing	Die-cast aluminum	Power Factor	> 0.95
Color	Black	Ambient Temp.	-80°C (-112°F) to 115°C (239°F)
Coating	C5M(standard) / PVDF optional		MIL-STD-810G (-80 °C) + MIL-STD-810H (+115 °C)
Inrush Current	Zero inrush current (0 Amp)	Weight	24.2Kg(53.4lb)
Beam Angle	70°	Lifetime	L70 15 years@55°C
Power Cord	600V / 200°C rated		L50 30 years@55°C
			1 years @115°C

ParagonLED Radiation Hardened Lighting



CERTIFIED
UL 1598

IP66



CB FC



LUMENS

70°
62,500 lm

(5000K)

WARRANTY

Ambient Temperature	Warranty Length
65°C (149°F) Max Ambient Temp.	7 Year Limited Warranty
85°C (185°F) Max Ambient Temp.	3 Year Limited Warranty
105°C (221°F) Max Ambient Temp.	1 Year Limited Warranty

TTL Getter System (optional) — extends lifetime to 3 years @105 °C. It continuously absorbs residual oxygen, moisture, and gases released from internal materials under high temperature, preventing oxidation and degradation.

Ordering Information

Series	Wattage	Color Temperature	Voltage	Beam Angle	Coating	Fixture color	
TTL	500 500W	40 4000K	120V	0 110°	0 PVDF	0 white	
		50 5000K	277V	1 70°	1 C5M	1 black	
			347V				
			480V				
			600V 250V				

Example:TTL-500-50-120V-011

TTL-RH has successfully completed fast-neutron irradiation at NARI Taiwan's TR-30/15 facility, receiving a $\sim 4.46 \times 10^{14}$ n/cm² fast-neutron fluence (1 MeV equivalent) under a 1–14 MeV spectrum during a 5-hour exposure.

The lighting unit remained fully functional after testing, confirming TTL-RH as the world's only commercial lighting platform with 1000 kGy gamma hardness and true survivability under 1–14 MeV fast-neutron irradiation.

Dimensions

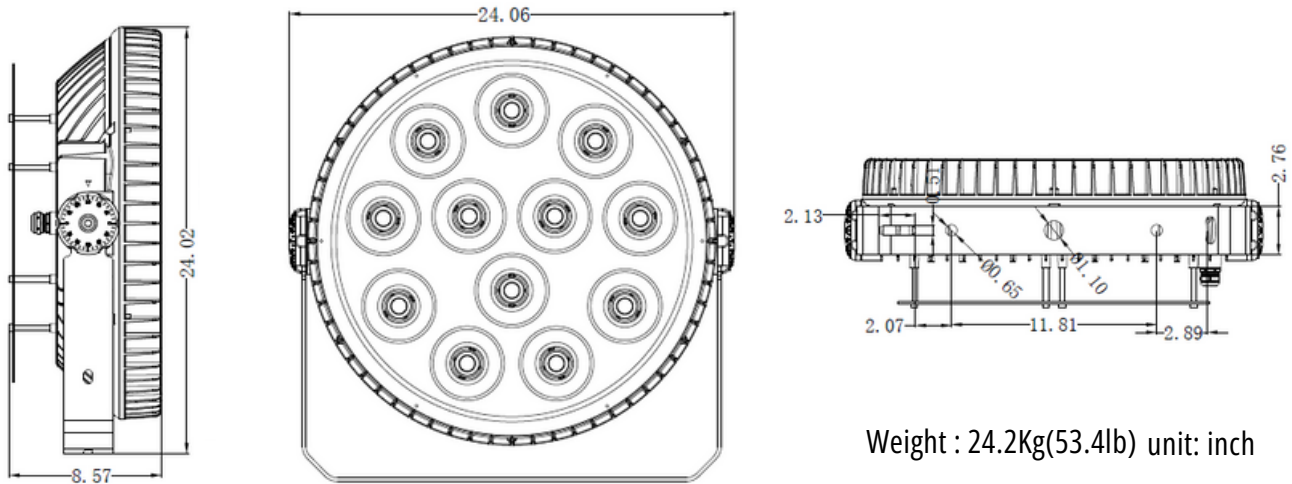

Weight : 24.2Kg(53.4lb) unit: inch

Photometrics

500W 70°

Polar Candela Distribution

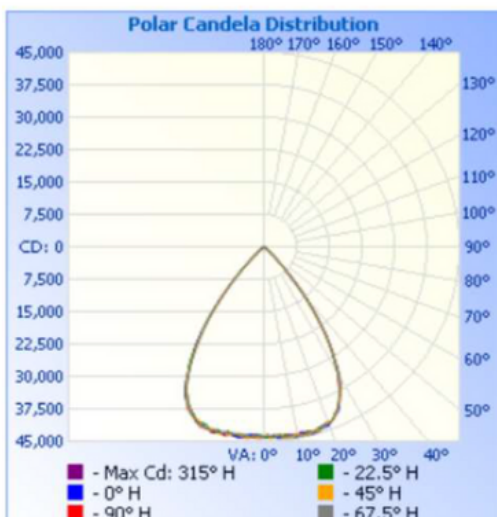

IsoCandela Plot

