

ParagonLED®

Product Catalog

TTL-XT (Extreme Temperatures Lighting)

MIL-STD-810G (-80 °C) + MIL-STD-810H (+115 °C)

www.thermal-tech-lighting.com



IP66





ParagonLED®

Company Profile

- 2008 – Company founded, establishing its focus on advanced AC COB LED technology
- 2010 – Achieved the world’s first CE certification for AC COB LED technology, setting a global benchmark.
- 2011 – Recognized as the first to gain both FCC and ErP certifications for AC COB LEDs.
- 2012 – Introduced the world’s first AC COB LED explosion-proof lighting and obtained UL certification.
- 2013 – Attained ISO9001:2008 certification and established the world’s first 3V–300V AC LM80 laboratory, certified by DOE and Energy Star.
- 2016 – Expanded to an annual production capacity of 6 million units, reinforcing large- scale manufacturing capability.
- 2017 – Set up the world’s first 600V AC LM80-certified laboratory, further strengthening reliability testing infrastructure.
- 2019 – Developed the world’s first ACCOB light engine with $T_c = 145^\circ\text{C}$, marking a breakthrough in high-temperature LED technology.
- 2020 – Deployed the extreme-environment ACCOB light engine (-80°C to $+115^\circ\text{C}$) into commercial operation at U.S. paper mills and steel mills. By 2025, more than 60,000 light engines have been successfully installed in these facilities.
- 2023 – Became a subsidiary of the AVC Group, enhancing global resources and thermal management expertise.
- 2025 – Completed the world’s first flip-chip ACCOB light engine designed for extreme temperatures.
- 2025 – Achieved a breakthrough in Nuclear Lighting: Successfully passed 1,000 kGy Gamma radiation and 4.46×10^{14} n/cm² Fast-neutron fluence testing at the National Atomic Energy Research Institute (NARI).
- Targeting PSE certification (100V/200V) for the Japanese market and UL certification (120V–600V) for linear models, paving the way for global expansion.



- **BLAST FURNACE**
USED TO EXTRACT MOLTEN IRON (PIG IRON) FROM IRON ORE. TEMPERATURE RANGE: 1,600°C TO 2,200°C.
- **ELECTRIC ARC FURNACE (EAF)**
USED FOR MELTING SCRAP STEEL OR DIRECT REDUCED IRON. TEMPERATURE RANGE: 1,600°C TO 1,800°C.

High Temperature Environment

ParagonLED is a pioneer in industrial lighting, pushing the boundaries of LED technology by extending operational temperature ranges from the conventional -25°C to 50°C to an impressive -80°C to $+115^{\circ}\text{C}$. This innovation is critical in industrial settings where extreme heat and challenging conditions demand reliable, high-performance lighting solutions. High-temperature resistant lighting is essential in industries such as:

1. **Steel Production and Forging:** Ensures safety and efficiency during processes like melting, forging, and rolling.
2. **Foundry Operations:** Withstands the intense heat of molten metal pouring and casting.
3. **Glass Manufacturing:** Functions reliably in extreme heat during the melting of raw materials.
4. **Ceramic Production:** Endures prolonged high-temperature firing in kilns.
5. **Coking Plants:** Handles the extreme temperatures of coal processing into coke.
6. **Heat Treatment Facilities:** Resists heat generated during the phase transitions of metals.

Specialized lighting design incorporates high-temperature resistant materials, cooling systems, and high IP ratings (IP66 or above) to protect against dust, heat, and corrosion.

Waste incineration plants also rely on high-temperature lighting to operate safely and efficiently. These systems must endure high heat, resist corrosive chemicals, and offer robust dust and moisture protection. Properly selected lighting ensures operational safety and reliability in these environments.

ParagonLED's expert assembly and testing teams provide unmatched technical support, guaranteeing the durability and performance of your lighting systems in even the most demanding conditions.

HOT SALE

TTL-XT — Extreme Temperatures Lighting



500W

63,000 LUMENS

- Beam Angle 70°
- 120VAC/277VAC/347VAC/480V AC/600VAC/250VDC
- 5000K color temperature
- -80°C (-112°F) to 115°C (239°F)
- MIL-STD-810G (-80 °C) + MIL-STD-810H (+115 °C)



45W

5,625 LUMENS

- Beam Angle 70°
- 120VAC/277VAC/347VAC/480V AC/600VAC/ 250VDC
- 5000K color temperature
- -80°C (-112°F) to 115°C (239°F)
- MIL-STD-810G (-80 °C) + MIL-STD-810H (+115 °C)



225W/350W

28,000~44,000 LUMENS

- Beam Angle 110°/70°
- 120VAC/277VAC/347VAC/480V AC/600VAC/250VDC
- 5000K color temperature
- -80°C (-112°F) to 115°C (239°F)
- MIL-STD-810G (-80 °C) + MIL-STD-810H (+115 °C)



10W~140W

1,250~18,000 LUMENS

- Beam Angle 110°
- 120VAC/277VAC/347VAC/480V AC/600VAC/250VDC
- 5000K color temperature
- -80°C (-112°F) to 125°C (257°F)
- MIL-STD-810G (-80 °C) + MIL-STD-810H (+115 °C)

TTL-XT Series

Extreme Temperatures Lighting

We use Nord-Lock washers for optimized safety performance.

NORD-LOCK
PART OF THE NORD-LOCK GROUP

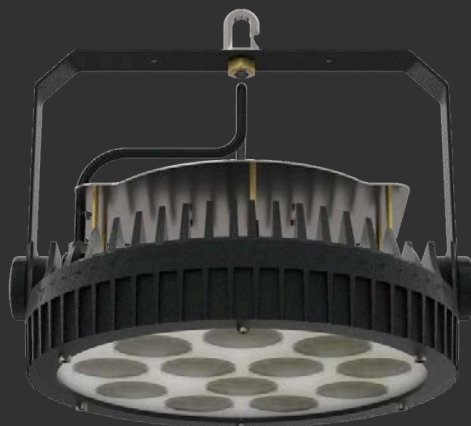

When you absolutely must have the

Toughest Industrial LED High Bay

MIL-STD-810G (-80 °C) + MIL-STD-810H (+115 °C)



High Ambient Temp.
-112°F (-80°C) to
239°F (115°C)



Field Replaceable LEDs



**C5M/PVDF
coating optional**



Chemical Repellent



**Instantaneous activation of
lighting function, without the
need for standby time.**



Anti-Glare

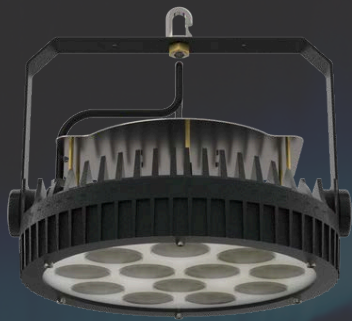

TTL-XT Series

Extreme Temperatures Lighting

“A real innovation in extreme environment LED lighting.”



Engineered and tested for reliable operation you can count on in temperatures ranging from **-112°F(-80°C) to 239°F(115°C)**



Game changing LEDmodule design (see details below). Replaceable to reduce the cost of long term ownership.



PVDF corrosion resistant coating over a die-cast aluminum housing + stainless steel hardware for incredible durability. 1,000 hour salt-fog test yielded no corrosion. [ASTM B117-19/ASTM D610-08(2019)]



Chemical repellent housing to stand up in areas where industrial chemicals are used or produced.



Instantaneous activation of lighting function, without the need for standby time.



Provide better eye protection and workplace safety.

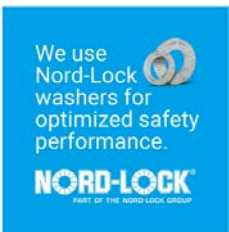

Nord-Lock wedge-locking washers consistently outperform alternative locking methods when it comes to securing bolted joints. This is proven by the results of thousands of Junker tests carried out for customers all over the world by Nord-Lock engineers.

When exposed to transverse vibrations underneath the bolt head, alternative locking methods such as plain washers, helical spring washers, check lock nuts, nylon inserted nuts and double nuts all show a loss of clamp load – loosening the bolt and exposing the joint to failure unless frequently retightened. So, Nord-Lock engineers would usually recommend wedge-locking washers to achieve the most secure bolted joint.

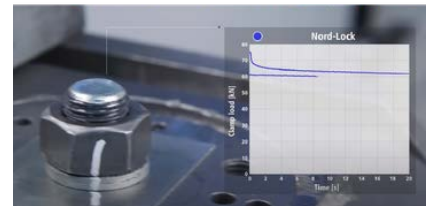
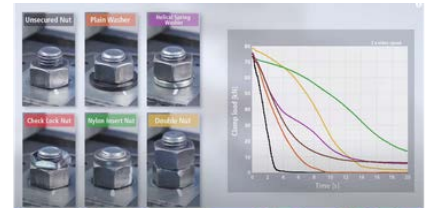

The heart of the TTL series is its revolutionary

DRIVER-ON-BOARD LED MODULE.

MIL-STD-810G (-80 °C) + MIL-STD-810H (+115 °C)

A marvel of engineering and innovative manufacturing processes, this proprietary module gives the TTL series outstanding light performance even in extreme hot and cold temperatures and requires no separate driver.

Over-Engineered

We use 12 IC current control chips when 4 would be enough for extra durability. Tested to 200° C without failure.

No Load Shedding

As modules approach their max. rated temperature, lumen output will not decrease. Reducing output at high temp. is a common occurrence with other high temp. lights.

1.2 mil Gold Wire

TTL series LEDs are connected with gold wire for enhanced durability under heavy thermal cycle stress.

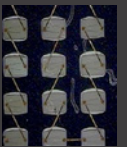

No Harmonic Distortion

Quality components and advanced circuit design results in longer fixture life and no line noise generated by the TTL series.

No Inrush Current

Inrush current has been engineered out of the module preventing large line voltage drops at start-up protecting the fixture and other equipment.

Waterproof/Thermal Coating

Special siliconebasedcoatingcreates a waterproof seal around the module and dissipates heat for increased durability.

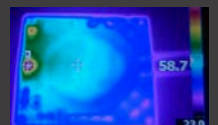

“Every component of the *TTL Series* was selected/ designed with **high ambient temperature** applications in mind.”



PVDF / C5M coating repels chemicals and prevents corrosion

Rugged die-cast aluminum housing

Metal reflector **70°** beam pattern ensures efficient light distribution.

Specialized ribbed silicone rubber gasket provides the perfect lens seal

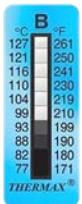

High temp thermostat label verifies highest temperature reached

Factory torqued and sealed stainless steel cable gland

Oversized cooling fins maximize thermal efficiency



304 Stainless Steel hook. Yield strength 600MPa

Heavy-duty #2 gauge mounting bracket 180° angle adjustment



Game changing proprietary driver-on-board LED modules are replaceable for extended fixture life and lower cost of ownership

Flat tempered glass lens provides impact protection, heat resistance and excellent optical clarity

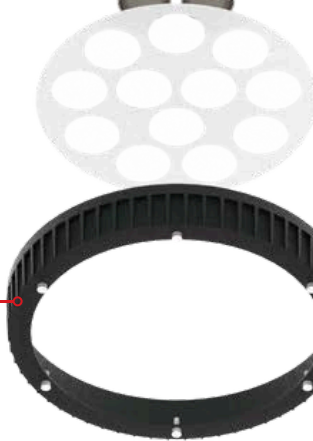

10' AWM style 4476 power cord is rated for 600V and 200°C

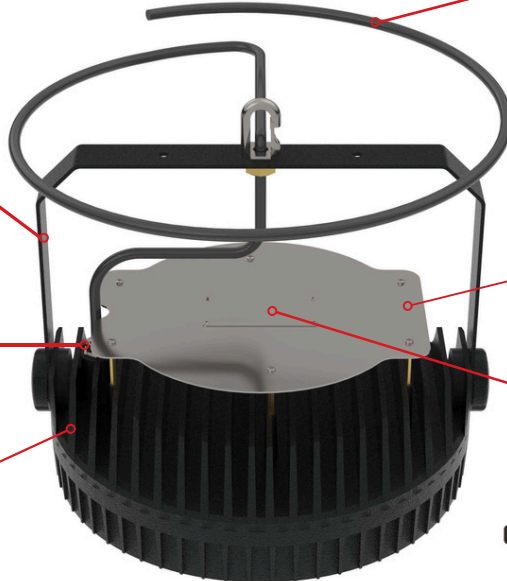

304 Stainless Steel Dust Cover

Stainless steel nameplate with registration QR code and fixture specifications



IP66



Technical Info

SPECIFICATIONS

Voltage	120VAC/277VAC/347VAC/480VAC/ 600VAC/250VDC
Wattage	500W (+/- 10%)
Color Temp	5000 Kelvin
Housing	C5M(standard) / PVDF optional
Color	Black(standard) / White optional
Lens	Flat tempered glass lens
CRI	>70
Efficacy	125 lm/W (500W)
Beam Angle	70°
Cable Gland	Stainless steel
Power Cord	600V / 200°C rated
Surge Protection	> 20KV
Ambient Temp.	-80°C (-112°F) to 115°C (239°F)

LUMENS

500W
62,500 lm

WARRANTY

Ambient Temperature	Warranty
65°C (149°F) Max Ambient Temp.	7 Year Limited Warranty
85°C (185°F) Max Ambient Temp.	3 Year Limited Warranty
105°C (221°F) Max Ambient Temp.	1 Year Limited Warranty
105°C (221°F) Max Ambient Temp.	3 Year Limited Warranty (optional)

TTL Getter System (optional) — extends lifetime to 3 years @105 °C. It continuously absorbs residual oxygen, moisture, and gases released from internal materials under high temperature, preventing oxidation and degradation.

PART NUMBERS

Part Number	Watt	Voltage
TTL-500-50-120V-1yz	500W	120VAC
TTL-500-50-277V-1yz		277VAC
TTL-500-50-347V-1yz		347VAC
TTL-500-50-480V-1yz		480VAC
TTL-500-50-600V-1yz		600VAC
TTL-500-50-250V-1yz		250VDC

x(Beam Angle)0=110° 1=70°
y(Coating) : 0=PVDF 1=C5M
z(Fixture color)0=white 1=black

MIL-STD-810G (-80 °C) + MIL-STD-810H (+115 °C)



IP66



DIMENSIONS :

Diameter : 562mm(22.1inch)
Height : 441mm(17.4inch)
Weight : 24.2Kg(53.4lb)

INDUSTRIAL APPLICATIONS

Primary Metal Fabrication
Steel Mills
Smelting Operations
Casting Foundries
Metal Polishing
Boiler Rooms

Blast Furnaces
Paint Curing
Ovens/Kilns
Pulp/Paper Production
Glass Manufacturing
Power Generation

Power Plants
Chemical Plants
Refineries
Aircraft Hangars
Ship Yards
Rail Yards

Aerospace Facilities
Industrial Freezers
Ice Manufacturing
Cryogenic Industries
cold-chain storage
overhead crane

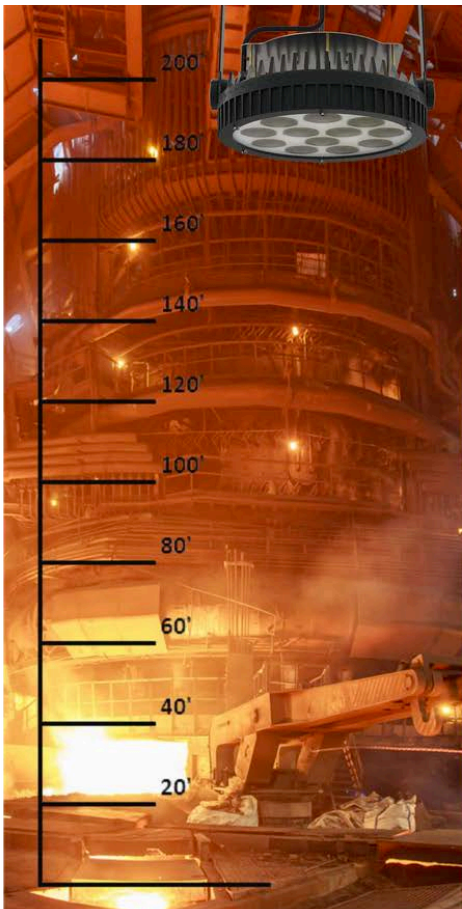

ACCESSORIES

Wire Guard



Visor



TTL-XT Series

Extreme Temperatures Lighting

We use Nord-Lock washers for optimized safety performance.

NORD-LOCK
PART OF THE NORD-LOCK GROUP

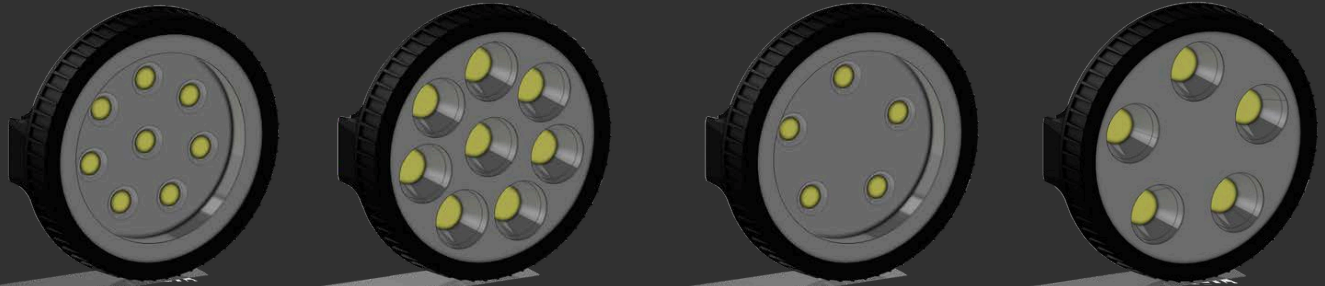

When you absolutely must have the

Toughest Industrial LED High Bay

MIL-STD-810G (-80 °C) + MIL-STD-810H (+115 °C)



High Ambient Temp.
-112°F (-80°C) to
239°F (115°C)



Field Replaceable LEDs



**PVDF/C5M
coating optional**



Chemical Repellent



**Instantaneous activation of
lighting function, without the
need for standby time.**



Anti-Glare

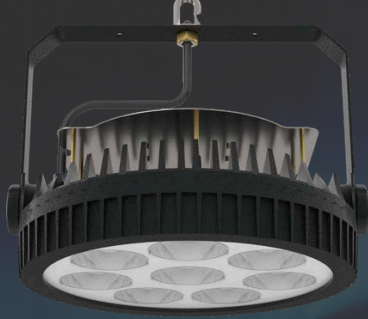

TTL-XT Series

Extreme Temperatures Lighting

“A real innovation in extreme environment LED lighting.”



Engineered and tested for reliable operation you can count on in temperatures ranging from **-112°F(-80°C) to 239°F(115°C)**



Game changing LEDmodule design (see details below). Replaceable to reduce the cost of long term ownership.



PVDF corrosion resistant coating over a die-cast aluminum housing + stainless steel hardware for incredible durability. 1,000 hour salt-fog test yielded no corrosion. [ASTM B117-19/ASTM D610-08(2019)]



Chemical repellent housing to stand up in areas where industrial chemicals are used or produced.



Instantaneous activation of lighting function, without the need for standby time.



Provide better eye protection and workplace safety.

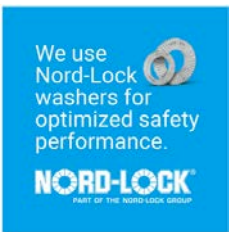

Nord-Lock wedge-locking washers consistently outperform alternative locking methods when it comes to securing bolted joints. This is proven by the results of thousands of Junker tests carried out for customers all over the world by Nord-Lock engineers.

When exposed to transverse vibrations underneath the bolt head, alternative locking methods such as plain washers, helical spring washers, check lock nuts, nylon inserted nuts and double nuts all show a loss of clamp load – loosening the bolt and exposing the joint to failure unless frequently retightened. So, Nord-Lock engineers would usually recommend wedge-locking washers to achieve the most secure bolted joint.

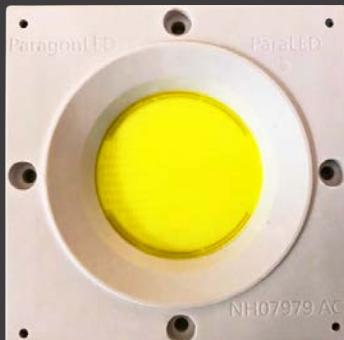
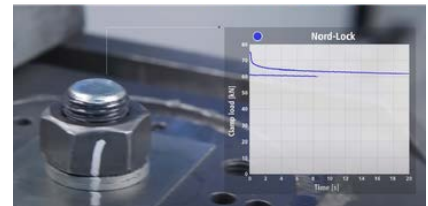
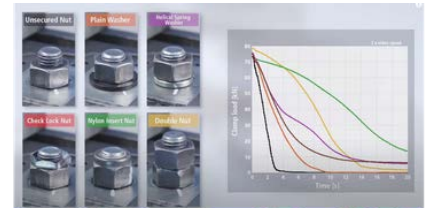

The heart of the TTL series is its revolutionary DRIVER-ON-BOARD LED MODULE.

MIL-STD-810G (-80 °C) + MIL-STD-810H (+115 °C)

A marvel of engineering and innovative manufacturing processes, this proprietary module gives the TTL series outstanding light performance even in extreme hot and cold temperatures and requires no separate driver.

Over-Engineered

We use 12 IC current control chips when 4 would be enough for extra durability. Tested to 200° C without failure.

No Load Shedding

As modules approach their max. rated temperature, lumen output will not decrease. Reducing output at high temp. is a common occurrence with other high temp. lights.

1.2 mil Gold Wire

TTLseriesLEDs are connected with gold wire for enhanced durability under heavy thermal cycle stress.



No Harmonic Distortion

Quality components and advanced circuit design results in longer fixture life and no line noise generated by the TTL series.

No Inrush Current

Inrush current has been engineered out of the module preventing large line voltage drops at start-up protecting the fixture and other equipment.

Waterproof/Thermal Coating

Special siliconebasedcoatingcreates a waterproof seal around the module and dissipates heat for increased durability.

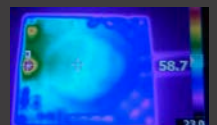

“Every component of the *TTL Series* was selected/ designed with **high ambient temperature** applications in mind.”



PVDF / C5M coating repels chemicals and prevents corrosion

Rugged die-cast aluminum housing

Metal reflector **70°** beam pattern ensures efficient light distribution.

110° beam pattern reflector optional

Specialized ribbed silicone rubber gasket provides the perfect lens seal

High temp thermostat label verifies highest temperature reached

Factory torqued and sealed stainless steel cable gland

Oversized cooling fins maximize thermal efficiency

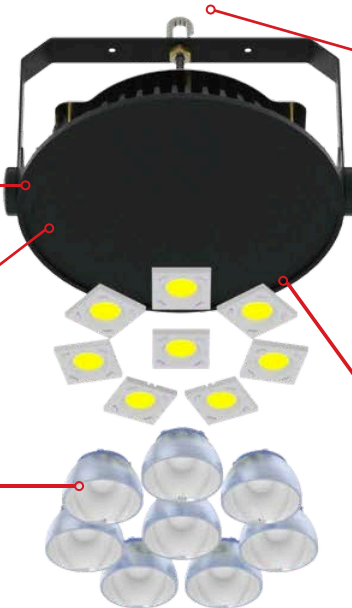

304 Stainless Steel hook. Yield strength 600MPa

Heavy-duty #2 gauge mounting bracket 180° angle adjustment



Game changing proprietary driver-on-board LED modules are replaceable for extended fixture life and lower cost of ownership

Flat tempered glass lens provides impact protection, heat resistance and excellent optical clarity



10' AWM style 4476 power cord is rated for 600V and 200°C

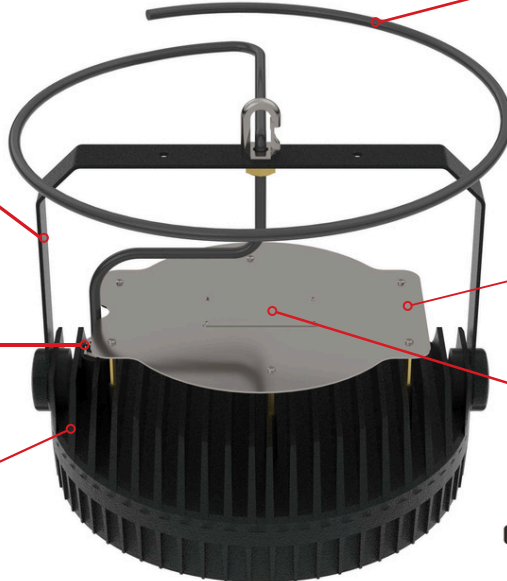

304 Stainless Steel Dust Cover

Stainless steel nameplate with registration QR code and fixture specifications

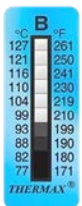

IP66



Technical Info

SPECIFICATIONS

Voltage	120VAC/277VAC/347VAC/480VAC/ 600VAC/250VDC
Wattage	225W/350W (+/- 10%)
Color Temp	5000 Kelvin
Housing	C5M(standard) / PVDF optional
Color	Black(standard) / White optional
Lens	Flat tempered glass lens
CRI	>70
Efficacy	125 lm/W
Beam Angle	70°/110°
Cable Gland	Stainless steel
Power Cord	600V / 200°C rated
Surge Protection	> 20KV
Ambient Temp.	-80°C (-112°F) to 115°C (239°F)

LUMENS

225W	350W
28,125 lm	43,750 lm

WARRANTY

Ambient Temperature	Warranty
65°C (149°F) Max Ambient Temp.	7 Year Limited Warranty
85°C (185°F) Max Ambient Temp.	3 Year Limited Warranty
105°C (221°F) Max Ambient Temp.	1 Year Limited Warranty
105°C (221°F) Max Ambient Temp.	3 Year Limited Warranty (optional)

TTL Getter System (optional) — extends lifetime to 3 years @105 °C. It continuously absorbs residual oxygen, moisture, and gases released from internal materials under high temperature, preventing oxidation and degradation.

PART NUMBERS

Part Number	Watt	Voltage
TTL-225-50-120V-1yz	225W	120VAC
TTL-225-50-277V-1yz		277VAC
TTL-225-50-347V-1yz		347VAC
TTL-225-50-480V-1yz		480VAC
TTL-225-50-600V-1yz		600VAC
TTL-225-50-250V-1yz		250VDC

Part Number	Watt	Voltage
TTL-350-50-120V-1yz	350W	120VAC
TTL-350-50-277V-1yz		277VAC
TTL-350-50-347V-1yz		347VAC
TTL-350-50-480V-1yz		480VAC
TTL-350-50-600V-1yz		600VAC
TTL-350-50-250V-1yz		250VDC

MIL-STD-810G (-80 °C) + MIL-STD-810H (+115 °C)

x(Beam Angle)0=110° 1=70°
y(Coating) : 0=PVDF 1=C5M
z(Fixture color)0=white 1=black



IP66



DIMENSIONS :

Diameter : 450mm(17.7inch)
Height : 373mm(14.7inch)
Weight : 15.3Kg(33.7lb)

INDUSTRIAL APPLICATIONS

Primary Metal Fabrication
Steel Mills
Smelting Operations
Casting Foundries
Metal Polishing
Boiler Rooms

Blast Furnaces
Paint Curing
Ovens/Kilns
Pulp/Paper Production
Glass Manufacturing
Power Generation

Power Plants
Chemical Plants
Refineries
Aircraft Hangars
Ship Yards
Rail Yards

Aerospace Facilities
Industrial Freezers
Ice Manufacturing
Cryogenic Industries
cold-chain storage
overhead crane



ACCESSORIES

welded wire mesh light guards





TTL-XT Series

Extreme Temperatures Lighting

“A real innovation in extreme environment LED lighting.”



Engineered and tested for reliable operation you can count on in temperatures ranging from **-112°F(-80°C) to 239°F(115°C)**



Game changing LEDmodule design (see details below). Replaceable to reduce the cost of long term ownership.



PVDF corrosion resistant coating over a die-cast aluminum housing + stainless steel hardware for incredible durability. 1,000 hour salt-fog test yielded no corrosion. [ASTM B117-19/ASTM D610-08(2019)]



Chemical repellent housing to stand up in areas where industrial chemicals are used or produced.



Instantaneous activation of lighting function, without the need for standby time.



Provide better eye protection and workplace safety.

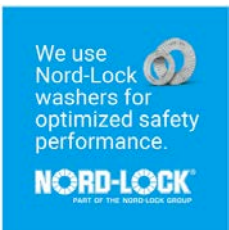

Nord-Lock wedge-locking washers consistently outperform alternative locking methods when it comes to securing bolted joints. This is proven by the results of thousands of Junker tests carried out for customers all over the world by Nord-Lock engineers.

When exposed to transverse vibrations underneath the bolt head, alternative locking methods such as plain washers, helical spring washers, check lock nuts, nylon inserted nuts and double nuts all show a loss of clamp load – loosening the bolt and exposing the joint to failure unless frequently retightened. So, Nord-Lock engineers would usually recommend wedge-locking washers to achieve the most secure bolted joint.

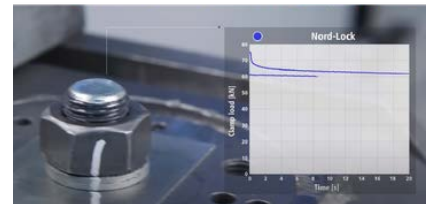
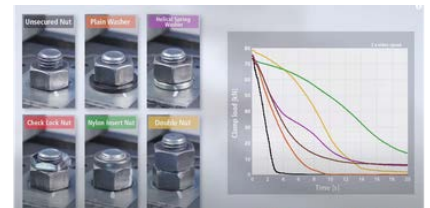

The heart of the TTL series is its revolutionary DRIVER-ON-BOARD LED MODULE.

MIL-STD-810G (-80 °C) + MIL-STD-810H (+115 °C)

A marvel of engineering and innovative manufacturing processes, this proprietary module gives the TTL series outstanding light performance even in extreme hot and cold temperatures and requires no separate driver.

Over-Engineered

We use 12 IC current control chips when 4 would be enough for extra durability. Tested to 200° C without failure.

No Load Shedding

As modules approach their max. rated temperature, lumen output will not decrease. Reducing output at high temp. is a common occurrence with other high temp. lights.

1.2 mil Gold Wire

TTLseriesLEDs are connected with gold wire for enhanced durability under heavy thermal cycle stress.

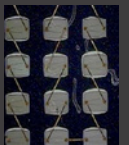

No Harmonic Distortion

Quality components and advanced circuit design results in longer fixture life and no line noise generated by the TTL series.

No Inrush Current

Inrush current has been engineered out of the module preventing large line voltage drops at start-up protecting the fixture and other equipment.

Waterproof/Thermal Coating

Special siliconebasedcoatingcreates a waterproof seal around the module and dissipates heat for increased durability.

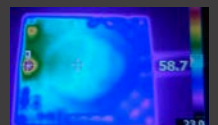

Technical Info

SPECIFICATIONS

Voltage 120VAC / 277VAC / 347VAC / 480VAC / 600VAC / 250VDC

Wattage 45W

Color Temp 4000K / 5000 K

Housing C5M coating

Color Black(standard)

Lens Flat tempered glass lens

Efficacy 125 lm/W

CRI >70

Beam Angle 70°

Cable Gland Stainless steel

Power Cord 600V / 200°C rated

Surge Protection > 15KV

Ambient Temp. -80°C (-112°F) to 115°C (239°F)

MIL-STD-810G (-80 °C) + MIL-STD-810H (+115 °C)

LUMENS

70°
5,625 lm

(5000K)

WARRANTY

Ambient Temperature	Warranty Length
65°C (149°F) Max Ambient Temp.	7 Year Limited Warranty
85°C (185°F) Max Ambient Temp.	3 Year Limited Warranty
105°C (221°F) Max Ambient Temp.	1 Year Limited Warranty
105°C (221°F) Max Ambient Temp.	3 Year Limited Warranty (optional)

TTL Getter System (optional) — extends lifetime to 3 years @105 °C. It continuously absorbs residual oxygen, moisture, and gases released from internal materials under high temperature, preventing oxidation and degradation.

Ordering Information

Series	Wattage	Color Temperature	Voltage	Beam Angle	Coating	Fixture color
TTL	45 W	40 4000K 50 5000K	120V 277V 347V 480V 600V 250V	1 70°	1 C5M	1 black

Example:TTL-45-50-120V-111

Dimensions

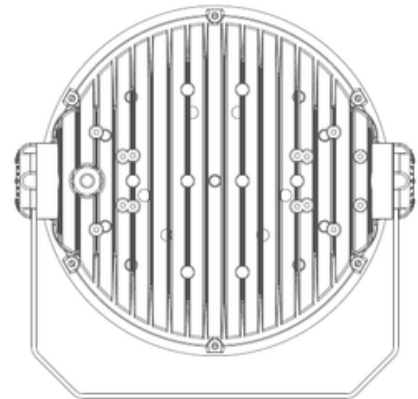
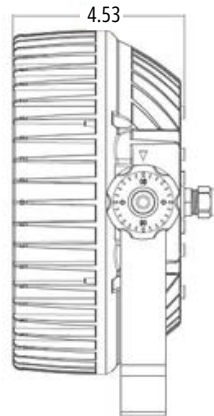
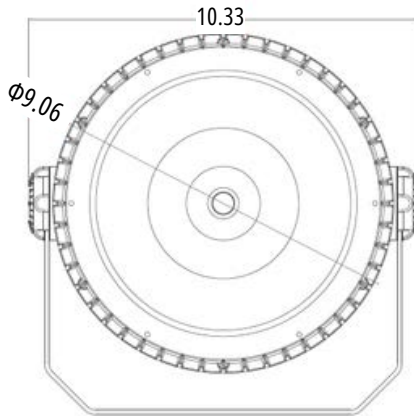

Weight : 3.2Kg(7.05lb) unit: inch



TTL-XT Series

Extreme Temperatures Lighting



When you absolutely must have the Toughest Industrial LED Task Light

MIL-STD-810G (-80 °C) + MIL-STD-810H (+115 °C)



High Ambient Temp.
-112°F (-80°C) to
257°F (125°C)



Field Replaceable LEDs



**Spraying Plastics/PVDF
coating optional**



Chemical Repellent



**Instantaneous activation of
lighting function, without the
need for standby time.**



Anti-Glare

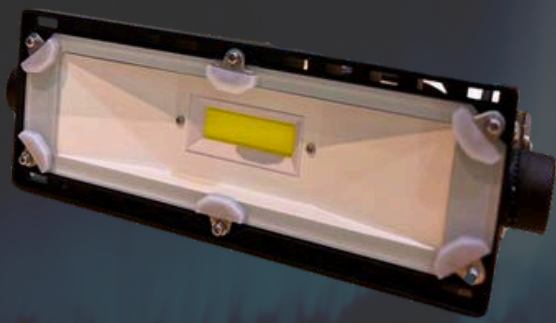

TTL-XT Series

Extreme Temperatures Lighting

“A real innovation in extreme environment LED lighting.”



Engineered and tested for reliable operation you can count on in temperatures ranging from **-112°F(-80°C) to 257°F(125°C)**



Game changing LED module design (see details below). Replaceable to reduce the cost of long term ownership.



PVDF corrosion resistant coating over a die-cast aluminum housing + stainless steel hardware for incredible durability. 1,000 hour salt-fog test yielded no corrosion. [ASTM B117-19/ASTM D610-08(2019)]



Chemical repellent housing to stand up in areas where industrial chemicals are used or produced.



Instantaneous activation of lighting function, without the need for standby time.



Provide better eye protection and workplace safety.



Nord-Lock wedge-locking washers consistently outperform alternative locking methods when it comes to securing bolted joints. This is proven by the results of thousands of Junker tests carried out for customers all over the world by Nord-Lock engineers. When exposed to transverse vibrations underneath the bolt head, alternative locking methods such as plain washers, helical spring washers, check lock nuts, nylon inserted nuts and double nuts all show a loss of clamp load – loosening the bolt and exposing the joint to failure unless frequently retightened. So, Nord-Lock engineers would usually recommend wedge-locking washers to achieve the most secure bolted joint.

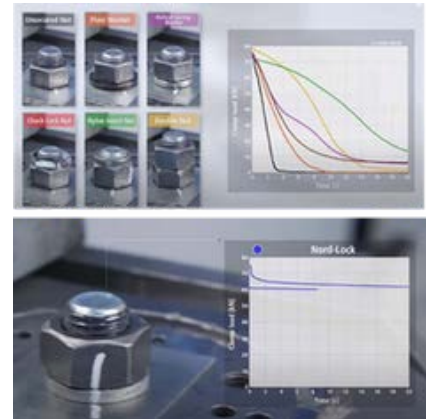

The heart of the TTL series is its revolutionary

DRIVER-ON-BOARD LED MODULE.

MIL-STD-810G (-80 °C) + MIL-STD-810H (+115 °C)

A marvel of engineering and innovative manufacturing processes, this proprietary module gives the TTL series outstanding light performance even in extreme hot and cold temperatures and requires no separate driver.

Over-Engineered

We use 12 IC current control chips when 4 would be enough for extra durability. Tested to 200° C without failure.

No Load Shedding

As modules approach their max. rated temperature, lumen output will not decrease. Reducing output at high temp. is a common occurrence with other high temp. lights.

1.2 mil Gold Wire

TTL series LEDs are connected with gold wire for enhanced durability under heavy thermal cycle stress.

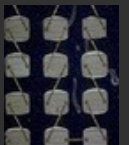

Low Harmonic Distortion

Quality components and advanced circuit design results in longer fixture life and no line noise generated by the TTL series.

Zero Inrush Current

Inrush current has been engineered out of the module preventing large line voltage drops at start-up protecting the fixture and other equipment.

Waterproof/Thermal Coating

Special silicone based coating creates a waterproof seal around the module and dissipates heat for increased durability.

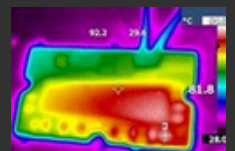

“Every component of the *TTL Series* was selected/designed with **high ambient temperature** applications in mind.”

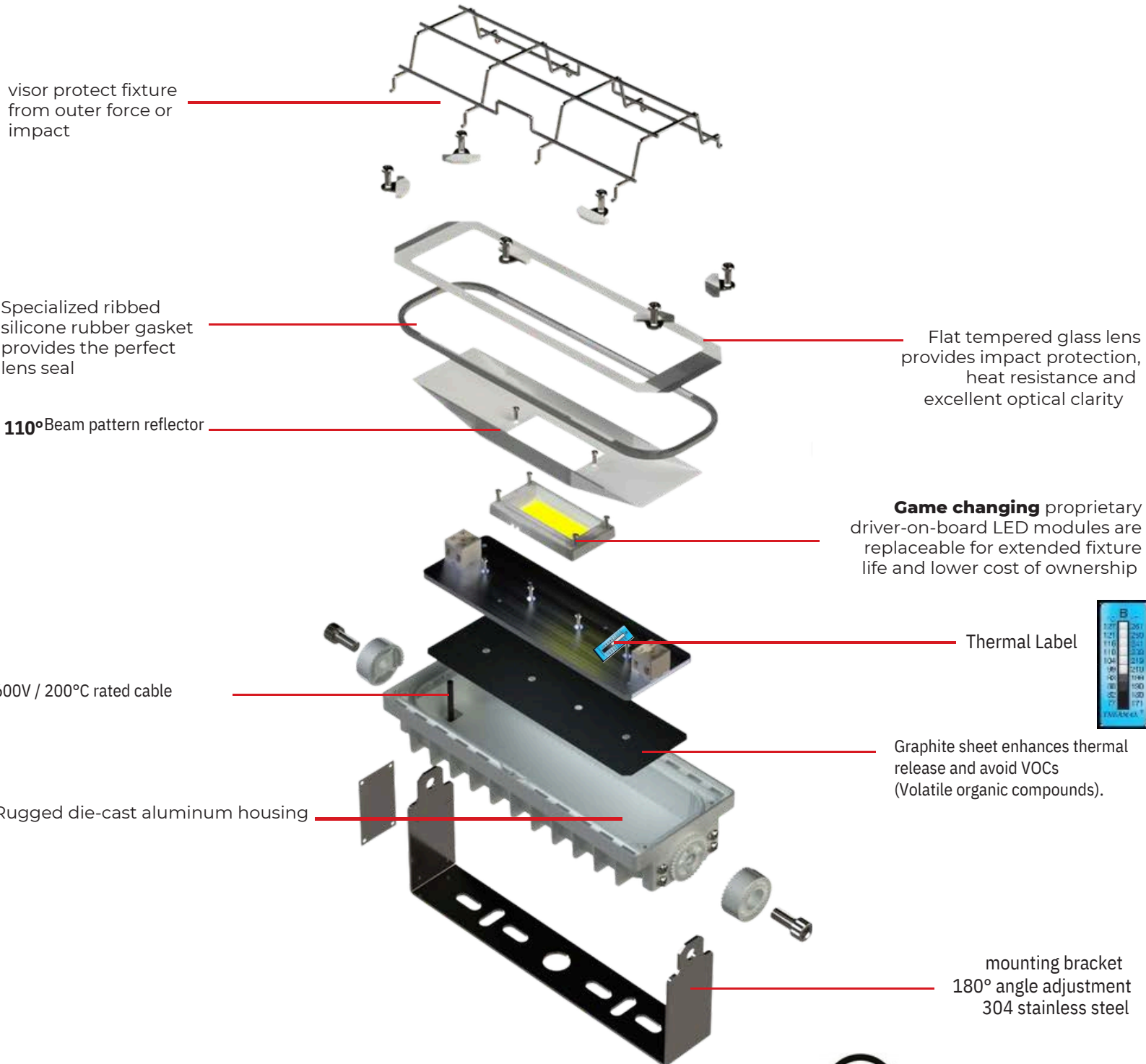

Technical Info

SPECIFICATIONS

Voltage 120VAC / 277VAC / 347VAC / 480VAC / 600VAC / 250VDC

Wattage 10W~140W

Color Temp 4000K / 5000 K

Housing Spraying Painting(standard) / PVDF optional

Color Black

Lens Flat tempered glass lens

Efficacy 125 lm/W (10W / 20W / 35W)

CRI >70

Beam Angle 110°

Cable Gland Stainless steel

Power Cord 600V /200°C rated

Surge Protection >15KV

Ambient Temp. -80°C (-112°F) to 125°C (257°F)

MIL-STD-810G (-80 °C) + MIL-STD-810H (+115 °C)

LUMENS

10W	20W	35W
1,250 lm	2,500 lm	4,375lm

(one unit, 5000K)

WARRANTY

Ambient Temperature	Warranty Length
65°C (149°F) Max Ambient Temp.	7 Year Limited Warranty
85°C (185°F) Max Ambient Temp.	3 Year Limited Warranty
105°C (221°F) Max Ambient Temp.	1 Year Limited Warranty
105°C (221°F) Max Ambient Temp.	3 Year Limited Warranty (optional)

TTL Getter System (optional) — extends lifetime to 3 years @105 °C. It continuously absorbs residual oxygen, moisture, and gases released from internal materials under high temperature, preventing oxidation and degradation.

Ordering Information

Example:TTL-040-50-120V-2

Series	Wattage	Color Temperature	Voltage	Unit	
TTL	010	10W	40 4000K	120V 120VAC	1 one unit
	020	20W	50 5000K	277V 277VAC	2 two units
	030	30W		347V 347VAC	3 three units
	035	35W		480V 480VAC	4 four units
	040	40W		600V 600VAC	
	060	60W		250V 250VDC	
	070	70W			
	080	80W			
	105	105W			
	140	140W			



IP66
IP68



DIMENSIONS :

One Unit	Two Unit	Three Unit	Four Unit
Width: 110mm(4.33inch)	Width: 110mm(4.33inch)	Width: 110mm(4.33inch)	Width: 110mm(4.33inch)
Length: 1ft	Length :2ft	Length : 3ft	Length : 4ft
Height:138.88mm(5.47inch)	Height :138.88mm(5.47inch)	Height :138.88mm(5.47inch)	Height :138.88mm(5.47inch)
Weight : 1.95Kg(4.30lbs)	Weight : 3.79Kg(8.36lbs)	Weight :5.37Kg(11.84lbs)	Weight :7.5Kg(16.5lbs)

INDUSTRIAL APPLICATIONS

Primary Metal Fabrication
Steel Mills
Smelting Operations
Casting Foundries
Metal Polishing
Boiler Rooms

Blast Furnaces Paint
Curing Ovens/Kilns
Pulp/Paper Production
Glass Manufacturing
Power Generation

Power Plants
Chemical Plants
Refineries
Aircraft Hangars
Ship Yards
RailYards

Aerospace Facilities
Industrial Freezers
Ice Manufacturing
Cryogenic Industries
cold-chain storage
overhead crane

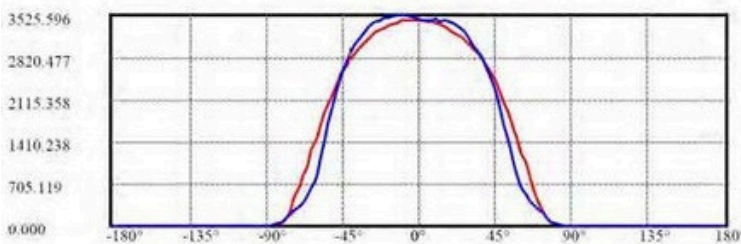
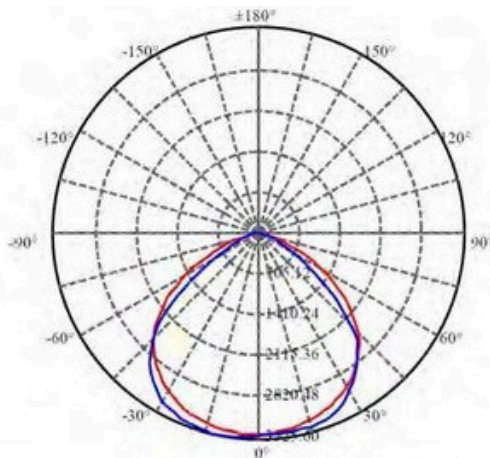

C0/C180: — (red line)
C90/C270: — (blue line)

ACCESSORIES

welded wire mesh light guards



IP66

IP68

Technical Info

DIMENSION

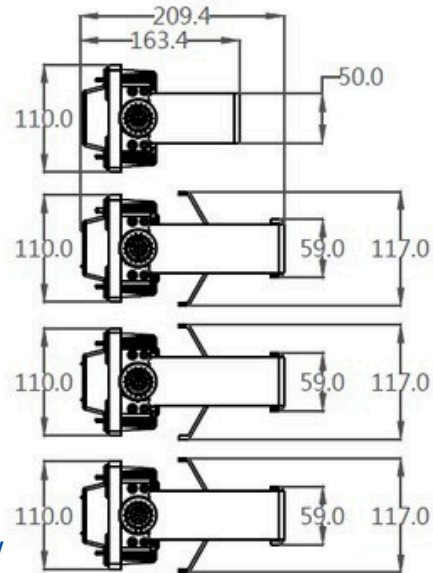
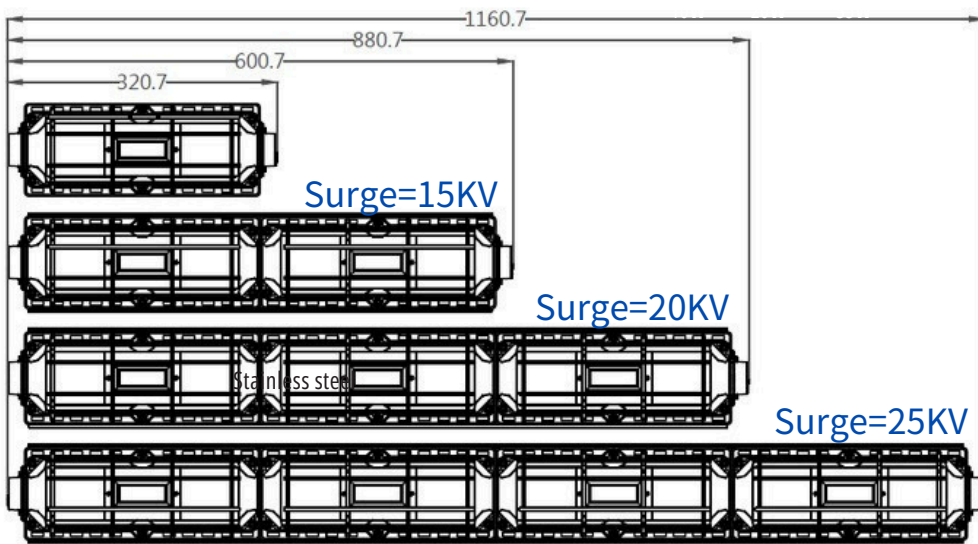

IP66

with wire guards, Unit: mm

CONFIGURATION

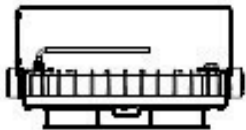

35W / 20W / 10W



70W / 40W / 20W



105W / 60W / 30W



140W / 80W / 40W

Technical Info

DIMENSION

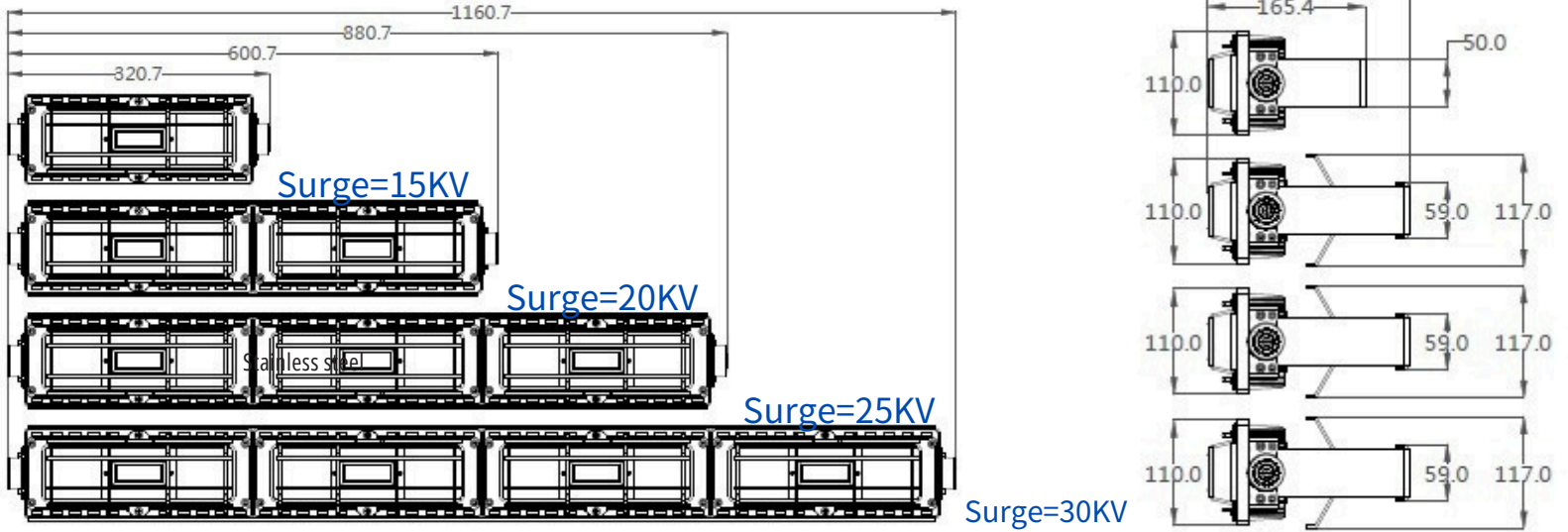

IP68

with wire guards, Unit: mm

CONFIGURATION

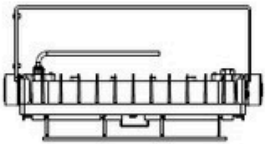

35W / 20W / 10W

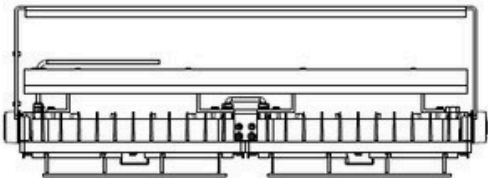

70W / 40W / 20W

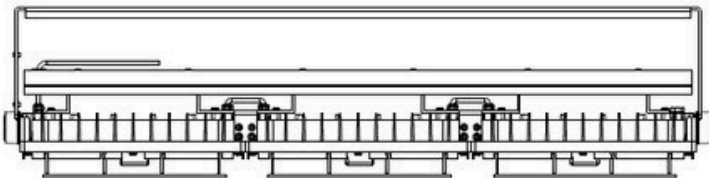

105W / 60W / 30W

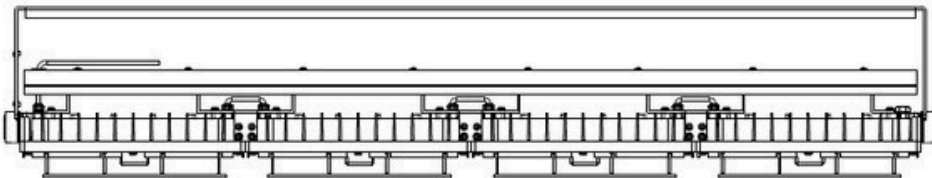

140W / 80W / 40W

Contact

HeadQuarters (Taiwan)

ADD: 3F., No. 369, Sec. 2, Wenhua 2nd Rd., Linkou Dist. NewTaipei City 244016, Taiwan (R.O.C.)

TEL: +886-2-2602-1066

FAX: +886-2-2601-0508

Chia Tin Chung, Ph.D

ct_chung@mac.com

US Office: 3333 S. Brea Canyon Road, #206 Diamond Bar, CA 91765, US

Morris Hsiao

morris.hsiao@paragonled.com

